

Portable insulation fault location system EDS3060/EDS3360 in combination with EDS460/461 systems



Portable insulation fault location systems EDS3060/EDS3360

Device features

- Insulation fault location system for IT systems incorporating an EDS460/461 system
- Response values: EDS3060 5 mA, EDS3360 0.5 mA
- LC display
- Alarm LED
- Switchable operating mode: insulation fault location/residual current measurement
- Supplied by an accumulator
- Accumulator charging set included in the scope of delivery
- RS-232 interface
- Current clamps 20/52 mm
- Current clamp 100 mm optional for EDS3060
- Residual current measurement in TN/TT systems
EDS3060: 10 mA...10 A
EDS3360: 10 mA...1 A

Approval



Product description

The EDS3060/3360 is a portable system designed to locate insulation faults in unearthed systems (IT systems). The robust aluminum case incorporates an EDS165/165-3 insulation fault evaluator, different types of current clamps as well as various accessories. The EDS3060/3360 system is intended to be used as system extension in electrical installations incorporating an EDS460/EDS461 system.

Application

- EDS3060 system for IT systems incorporating an EDS460 system
- EDS3360 system for IT systems incorporating an EDS461 system
- For insulation fault location in system circuits not being monitored by measuring current transformers.

Function

Once the installed IRDH575 insulation monitoring device or the PGH... insulation fault test device has been activated, the measuring clamps of the portable EDS165/165-3 evaluator are placed around all conductors of the individual circuits (with the exception of PE). When the measuring value in a faulty subcircuit exceeds the response value, the alarm LED lights up and an audible signal sounds. The value of the test current is indicated on the display. The alarm message can be stored. Not only can current clamps be used to detect the measuring values, but also permanently installed or split-core measuring current transformers.

An additional function allows measuring residual currents in earthed power supplies (TN/TT systems) too. The operating mode can be changed via a selector switch. Residual currents in the range of 10 mA...1 A (EDS165-3) resp. 10 mA...10 A (EDS165) can be measured.

Displays

The LC display indicates the measured value of the test current, the type of the connected measuring current transformers resp. current clamps, the accumulator capacity, the activation of the alarm memory, the activation of the buzzer, and the set nominal frequency.

Technical data EDS3060/3365

Insulation coordination acc. to IEC 60664-1

Rated insulation voltage	EDS3060 AC 500 V, EDS3360 AC 250 V
Rated impulse voltage/pollution degree	4 kV/3

Voltage ranges

Nominal system voltage U_n	see ordering information
Supply voltage U_s	see ordering information
Operating range of U_s	0.85...1.15 x U_s
Power consumption	≤ 3 VA
Storage battery charger	AC 100...240 V

Response values

Test current response value	EDS3060 5 mA; EDS3360 0.5 mA
-----------------------------	------------------------------

Outputs

Interface	RS-232
-----------	--------

Display

LC Display	2 x 16 characters
LED	Alarm

General Data

Shock resistance IEC 60068-2-27 (during operation)	15 g/11 ms
Bumping IEC 60068-2-29 (during transport)	40 g/6 ms
Vibration resistance IEC 60068-2-6 (during operation)	1 g/10...150 Hz
Vibration resistance IEC 60068-2-6 (during transport)	2 g/10...150 Hz
Ambient temperature (during operation)	-10 °C...+55 °C
Ambient temperature (during storage)	-40 °C...+70 °C
Climatic class acc. to DIN IEC 60721-3-3	3K5
Operating mode	continuous operation
Mounting	any position
Degree of protection acc. to DIN EN 60529	IP 20
Flammability class	UL94V-0
Product standards	DIN EN 61557-9: 2000-08 EN 61557-9: 1999-11, IEC 61557-9: 1999-09
Operating manual	EDS3060 TGH1266; EDS3360 TGH1320
Weight	≤ 7000 (≤ 8500 g including PSA3165)

Ordering information

Type	Supply-voltage U_s	Nominal system-voltage U_n	Art. No.
EDS3060	--	--	B 9108 2006
EDS3360	--	--	B 9108 2013
EDS3065	AC 230 V	AC 20...575 V, DC 20...504 V*	B 9108 2004
EDS3065-13**	AC 90...132 V*	AC 20...575 V, DC 20...504 V*	B 9108 2005
EDS3365	AC 230 V	AC 20...265 V, DC 20...308 V*	B 9108 2011
EDS3365-13**	AC 90...132 V*	AC 20...265 V, DC 20...308 V*	B 9108 2012

** without charging set

* absolute values

Portable insulation fault location systems EDS3065/EDS3365



Portable insulation fault location systems EDS3065/EDS3365

Device features

- Insulation fault location system for IT systems EDS3065 AC 20...575 V/DC 20...504 V – EDS3365 AC 20...265 V/DC 20...308 V
- Response values: EDS3065 5 mA, EDS3365 0.5 mA
- LC display
- Alarm LED
- Switchable operating mode: insulation fault location/residual current measurement
- Supplied by an accumulator
- Accumulator charging set included in the scope of delivery
- RS-232 interface
- Current clamps 20/52 mm
- Current clamp 100 mm optional for EDS3065
- Residual current measurement in TN/TT systems EDS3065: 10 mA... 10 A EDS3365: 10 mA... 1 A
- Portable insulation fault test device

Approval



Product description

The EDS3065/3365 is a portable system designed to locate insulation faults in unearthed systems (IT systems). The EDS3065 is designed to be used in AC 20...575 V/DC 20...504 V systems, the EDS3365 is designed to be used in AC 20...265 V/DC 20...308 V. The robust aluminium case incorporates an EDS165/165-3 insulation fault evaluator, a PGH18... insulation fault test device, different types of current clamps as well as various accessories.

Application

- EDS3065 system for insulation fault location in main circuits
- EDS3365 system for insulation fault location in control circuits
- For occasional location of insulation faults in small or medium-sized IT systems

Function insulation fault test device

The PGH18... insulation fault test device should be connected preferably at the power supply infeed of the system being monitored. Once being switched on, the PGH18... generated a defined test current signal. The existing system voltage is used to drive the test current. The test current generated in this manner depends on the size of the present insulation fault and the system voltage. The test current is limited to 25/2.5 mA resp. 10/1 mA, depending on the switch position and device type. The cycle of the test current is indicated via alarm LEDs.

Function insulation fault evaluator

Once the installed PGH185/183 insulation fault test device has been activated, the measuring clamps of the portable EDS165/-3 evaluator are placed around all conductors of the individual circuits (with the exception of PE). When the measuring value in a faulty subcircuit exceeds the response value, the alarm LED lights up and an audible signal sounds. The value of the test current is indicated on the display. The alarm message can be stored. Not only can current clamps be used to detect the measuring values, but also permanently installed or split-core measuring current transformers.

An additional function allows measuring residual currents in earthed systems (TN/TT systems) too. The operating mode can be changed via a selector switch. Residual currents in the range of 10 mA...1 A (EDS165-3) resp. 10 mA...10 A (EDS165) can be measured.

Displays

The LC display indicates the measured value of the test current, the type of the connected measuring current transformers resp. current clamps, the accumulator capacity, the activation of the alarm memory, the activation of the buzzer, and the set nominal frequency.

Technical data EDS3360/3365

Insulation coordination acc. to IEC 60664-1

Rated insulation voltage	EDS3065 AC 500 V, EDS3365 AC 250 V
Rated impulse voltage/pollution degree	4 kV/3

Voltage ranges

Nominal system voltage U_n	see ordering information
Supply voltage U_S	see ordering information
Operating range of U_S	0.85...1.15 x U_S
Power consumption	≤ 3 VA
Storage battery charger	AC 100...240 V

Test current

Selectable, max. value	EDS 3065 10/25 mA; EDS3365 1/2.5 mA
------------------------	-------------------------------------

Response values

Test current response value	EDS 3065 5 mA; EDS3365 0.5 mA
-----------------------------	-------------------------------

Outputs

Interface	RS-232
-----------	--------

Displays

LC display	LC 2 x 16 characters
LED	Alarm

General data

Shock resistance IEC 60068-2-27 (during operation)	15 g/11 ms
Bumping IEC 60068-2-29 (during transport)	40 g/6 ms
Vibration resistance IEC 60068-2-6 (during operation)	1 g/10...150 Hz
Vibration resistance IEC 60068-2-6 (during transport)	2 g/10...150 Hz
Ambient temperature (during operation)	-10 °C...+55 °C
Ambient temperature (during storage)	-40 °C...+70 °C
Climatic class acc. to DIN IEC 60721-3-3	3K5
Operating mode	continuous operation
Mounting	any position
Degree of protection acc. to DIN EN 60529	IP 20
Flammability class	UL94V-0
Product standards	DIN EN 61557-9: 2000-08 EN 61557-9: 1999-11, IEC 61557-9: 1999-09
Operating value	EDS3065 TGH 1266; EDS3365 TGH1320
Weight	≤ 7000 g (≤ 8500 g with PSA3165)

EDS3070

Portable insulation fault location system for unearthed systems (IT systems)



EDS3070

Device features

- Insulation fault location system for IT systems AC 42...460 Hz 0...575 V DC 0...504 V
- Less time and man power for maintenance due to precise localisation of the point of fault
- Measuring clamps 20/52 mm (115 mm optional)

Test device PGH186

- Variable test current 10/25 mA
- Integrated power supply unit for de-energized (disconnected) systems

EDS165 evaluator

- Response value 5 mA
- Measuring clamps 20/52 mm included in the scope of delivery
- Supplied by an accumulator (charging set included in the scope of delivery)
- Switchable operating mode insulation fault location/residual current measurement (AC 45...65 Hz, 10 mA...10 A)
- RS-232 interface

Product description

The EDS3070 is a portable system designed to locate insulation faults in unearthed systems (IT systems).

Owing to the integrated voltage source it is intended to be used in de-energized systems. The robust aluminium case incorporates an EDS165 insulation fault evaluator, a PGH186 insulation fault test device, different types of current clamps as well as various accessories.

Under specified conditions, insulation faults can also be located in earthed systems (TN-S systems).

Applications

- Insulation fault location in IT main circuits, in particular also in de-energized (disconnected) systems
- Can also be used in TN-S systems where all poles are de-energized

Function

Insulation fault test device PGH

The PGH186 insulation fault test device should be connected preferably at the power supply infeed of the system being monitored. Once being switched on, the PGH186... generated a defined test current signal. The existing system voltage is used to drive the test current. The test current generated in this manner depends on the size of the present insulation fault and the system voltage. The test current is limited to max. 25/10 mA. If no system voltage exists (disconnected system), the test current will be generated by the integrated voltage source. The device automatically checks whether system voltage is present or not, no setting required. The cycle of the test current is indicated via alarm LEDs.

Insulation fault evaluator

Once the installed PGH186 insulation fault test device has been activated, the measuring clamps of the portable EDS165 evaluator are placed around all conductors of the individual circuits (with the exception of PE). When the measuring value in a faulty subcircuit exceeds the response value, the alarm LED lights up and an audible signal sounds. The value of the test current is indicated on the display. The alarm message can be stored. Not only can current clamps be used to detect the measuring values, but also permanently installed or split-core measuring current transformers.

Additional functions

An additional function allows measuring residual currents in earthed power supplies (TN/TT systems) too. The operating mode can be changed via a selector switch. Residual currents in the range of AC 45...65 Hz, 10 mA...10 A can be measured.

Displays

The LC display indicates the measured value of the test current, the type of the connected measuring current transformers resp. current clamps, the accumulator capacity, the activation of the alarm memory, the activation of the buzzer, and the set nominal frequency.

Application example: Insulation fault location in unearthed power supplies (IT systems)

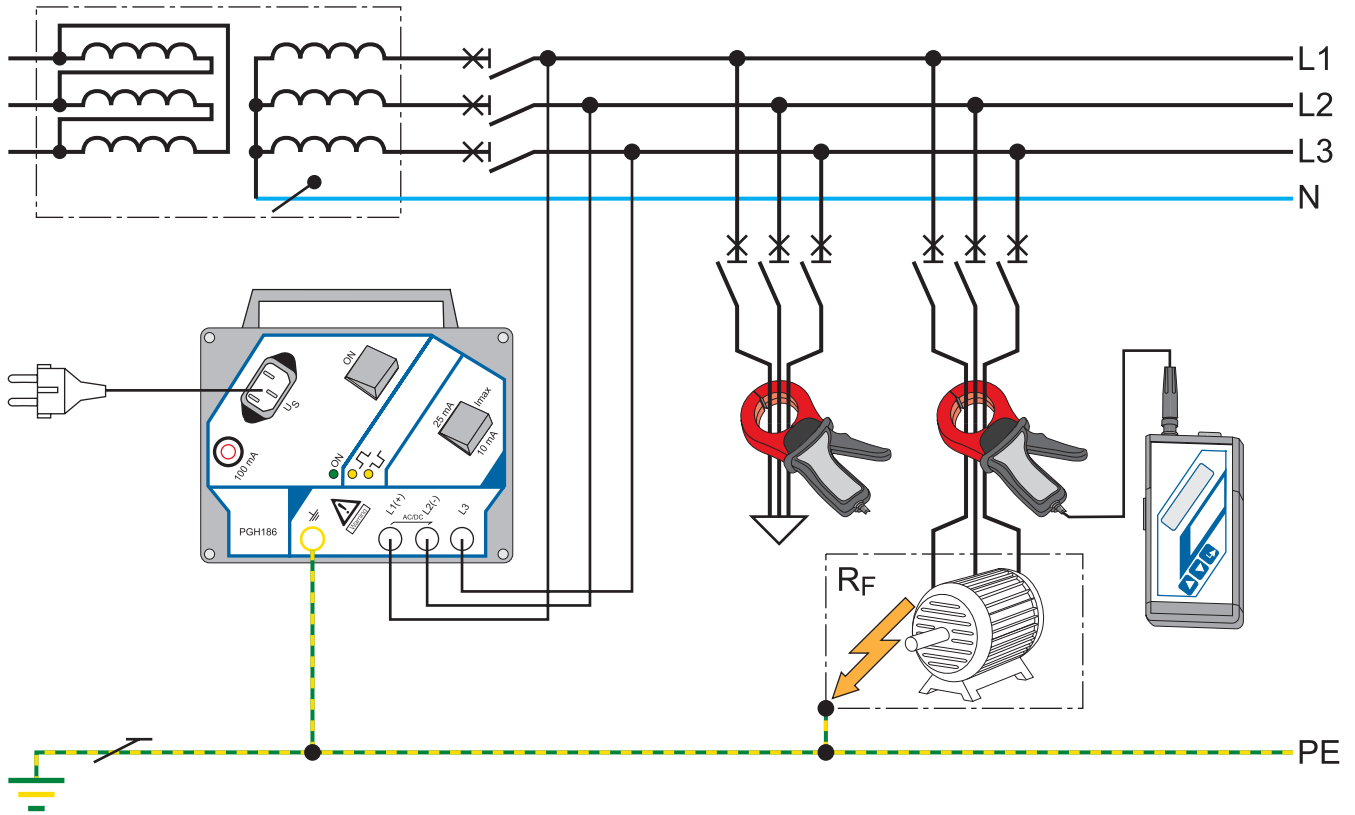

**Application example: Insulation fault location in an earthed system (TN-S system) (switch open, all poles of the system disconnected)
Residual current measurement (switch closed)**

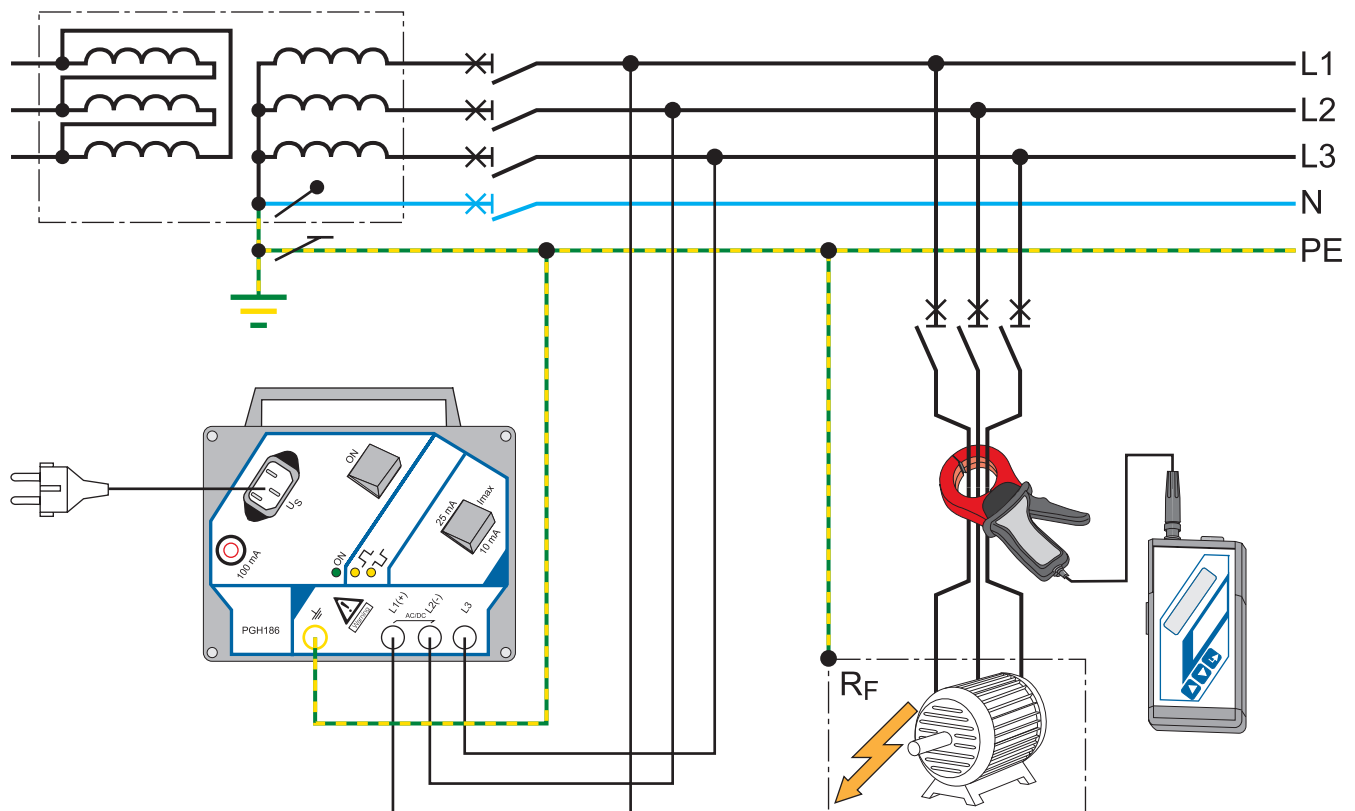

1.7

Operating elements EDS186

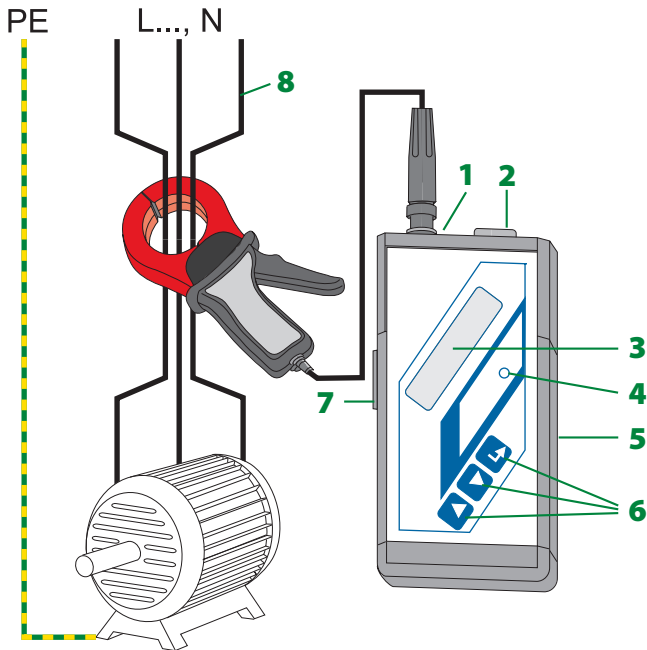

- 1 - BNC socket for connection of the measuring clamps or measuring current transformers
- 2 - RS-232 interface
- 3 - LC display
- 4 - Alarm LED "U>Y"
- 5 - Power supply unit connection (mounted laterally)
- 6 - Function keys
- 7 - Selector switch "operating modes" (located laterally)
- 8 - Cable in direction to the load (without PE)

Operating elements PGH186

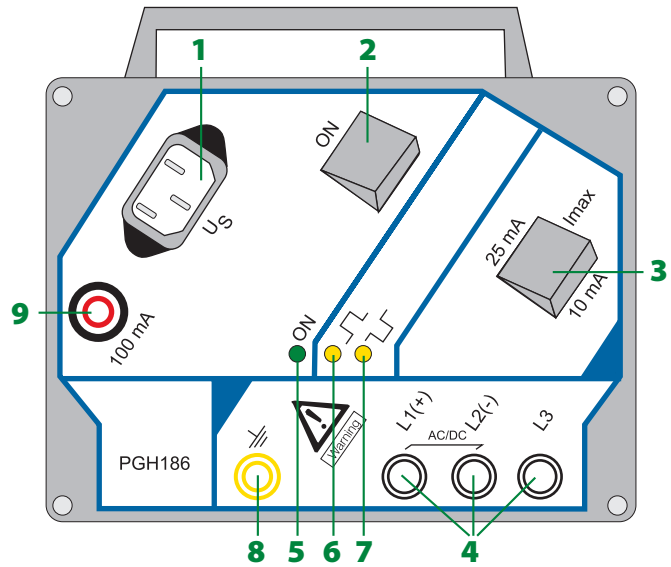

- 1 - Connector for cold conditions for power supply
- 2 - On/Off switch
- 3 - Selector switch for maximum test current
- 4 - Sockets for system coupling
- 5 - Power On LED "ON"
- 6 - Alarm LED indicating that the positive test pulse is active
- 7 - Alarm LED indicating that the negative test pulse is active
- 8 - Socket for PE connection
- 9 - Fuse power supply unit, fast micro-fuse 5 x 20mm 100 mA
- 10 - Located on the back of the device: Magnetic adhesive strip at the back of the enclosure for mounting to metal parts (control cabinet)

Technical data
Insulation coordination acc. to IEC 60664-1/IEC 60664-3

Rated insulation voltage	AC 500 V
Rated impulse voltage/pollution degree	4 kV / III

Supply voltage devices

Supply voltage U_s	
Test device PGH186	AC 230 V
Frequency range U_s	50...60 Hz
Operating range U_s	0.85...1.15 x U_s
Power consumption	≤ 3 VA
Accumulator charging set	AC 100...240 V

Test circuit PGH186

Test current, selectable	10/25 mA
Measuring voltage	DC 50 V

Response values EDS165

Response value, test current	5 mA
Measuring range residual current measurement	AC 45...65 Hz, 10 mA...10 A

EMC

EMC	IEC 62020: 2003-11
Operating temperature	-10 °C...+55 °C

Classification of climatic conditions IEC 60721

Stationary use (IEC 60721-3-3)	3K5 (except condensation and formation of ice)
Transportation (IEC 60721-3-2)	2K3 (except condensation and formation of ice)
Storage (IEC 60721-3-1)	1K4 (except condensation and formation of ice)

Classification of mechanical conditions acc. to IEC 60721:

Stationary use (IEC 60721-3-3)	3M4
Transportation (IEC 60721-3-2)	2M2
Storage (IEC 60721-3-1)	1M3

Other

Operating mode	continuous operation
Position of normal use	any
Degree of protection, terminals (IEC 60529)	IP20
Enclosure material	polycarbonate
Flammability class	UL94V-0
Product standards	DIN EN 61557-9: 2000-08 EN 61557-9: 1999-11, IEC 61557-9: 1999-09
Operating manual	TGH1398
Weight	≤ 7 kg (≤ 8.5 kg with PSA3165)

Ordering information

Type	Supply voltage	Art. No.
EDS3070	AC 50...60 Hz 230 V	B 9108 2018
PSA3165	Measuring clamp ø 115 mm	B 980 852

Dimension diagram device carrying case

Dimensions are given in mm

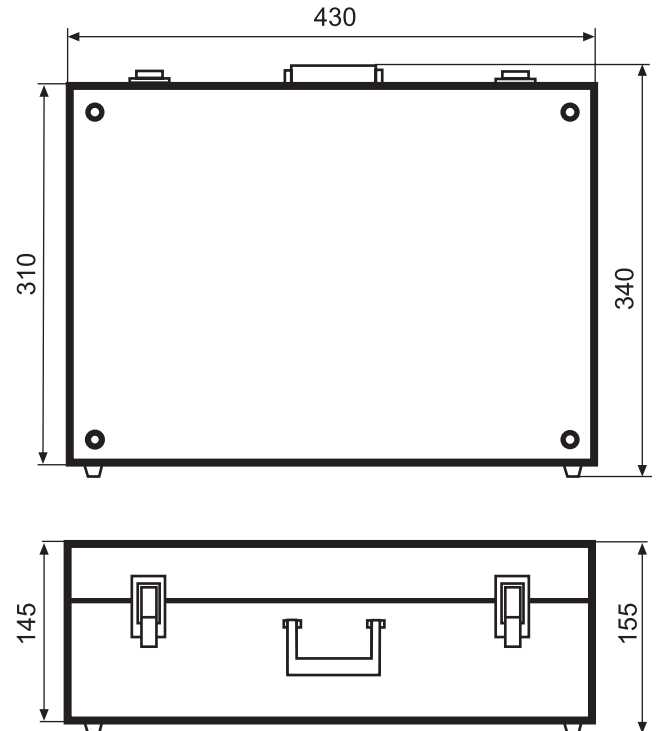

EDS3065 system – Accessory

Coupling device AGE185



AGE185

Coupling device AGE185

The EDS3065 system is designed to monitor and query IT systems of AC, 3(N)AC, 20...575 V and DC 20...504 V.

When using the coupling device AGE185, AC IT systems up to 790 V and DC IT systems up to 960 V can be monitored.

Connection PGH185 insulation fault test device and coupling device AGE185

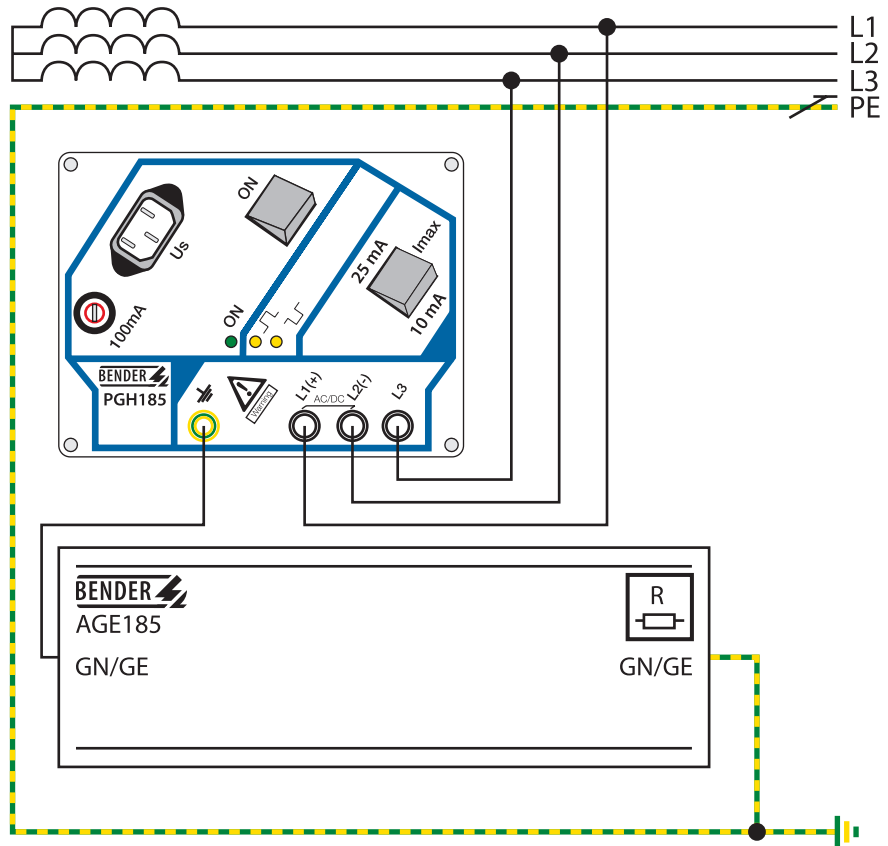

Ordering information

Type	Nominal system voltage U_n	Art. No.
AGE185	AC, 3(N)AC 500...790 V/DC 400...960 V	B 980 305

Approvals

All EDS system components have the following approvals:

