

## A-ISOMETER® IR1575

Insulation monitoring device  
for unearthed AC/3(N)AC, DC systems



A-ISOMETER® IR1575

### Device features

- Insulation monitoring for unearthed systems AC, AC/DC 0 ... 480 V, DC 0 ... 480 V
- Two separately adjustable response values 2 kΩ ... 1 MΩ
- AMP measuring principle
- Automatic adaptation to the system leakage capacitance
- Alarm LEDs: Alarm 1/Alarm 2
- Fault memory behaviour, selectable
- Connection monitoring system/earth
- Test and reset button
- Connection external test/reset button
- Two separate alarm relays with one changeover contact each
- N/O or N/C operation
- Backlit LC display
- Self monitoring with automatic alarm message
- Plug-in terminals
- Enclosure for door mounting 96 x 96 mm

### Approvals



### Product description

The A-ISOMETER® of the IR1575 series is designed to monitor the insulation resistance of unearthed main circuits (IT systems) AC, AC/DC 30...480 V resp. DC 0...480 V.

The AMP measuring principle allows the Isometers to be used in systems with directly connected DC components. The IR1575 automatically adapts itself to the existing system leakage capacitances. An external supply voltage allows de-energized systems to be monitored too.

Please note that the frequency range of the IR1575 is limited to DC, 30...420 Hz. For use in systems containing variable-speed drives, we recommend to use the IRDH275/375 version.

### Application

- AC or AC/DC main circuits
- AC/DC main circuits with directly connected DC components
- UPS systems, battery systems
- Heaters with phase control
- Systems including switched-mode power supplies

### Function

When the insulation resistance between the system conductors and earth falls below the set response value, the alarm relays switch and the alarm LEDs light up. Two separately adjustable response values/alarm relays allow a distinction to be made between prewarning and alarm. The measured value is indicated on the LC display. The fault message can be stored. The fault memory can be reset by pressing the reset button. By pressing the test button, the function of the device as well as the connections to system and earth can be tested. When a fault occurs during this test, it will be signalled by alarm relay K2. The parameterization of the device can be carried out via the LC display or the function keys integrated in the front plate.

### Measuring principle



The A-ISOMETER® of the IR1575 series uses the patented AMP measuring principle (refer to chapter Annex – "Technical aspects...").

Wiring diagram – Operating elements

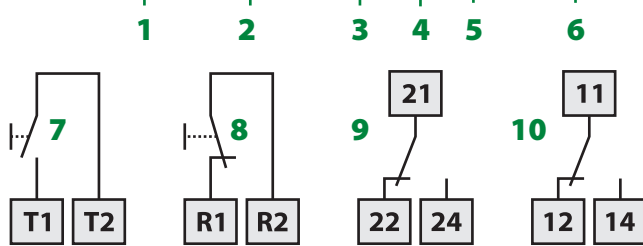
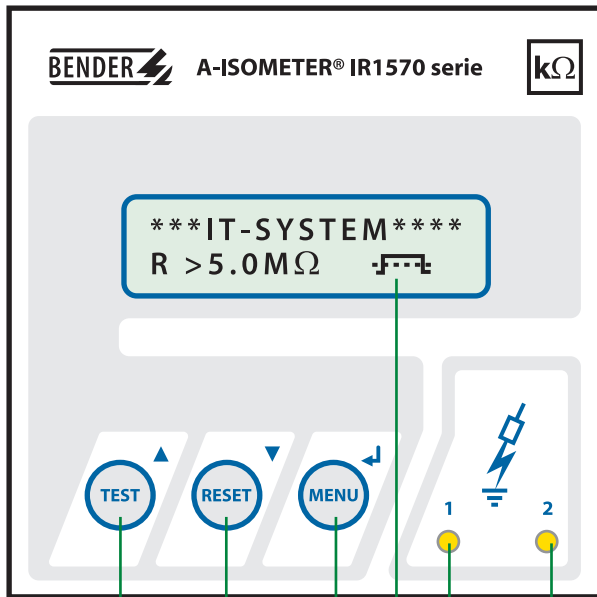

- 1 - TEST button: to call up the self test.  
Arrow up key: Parameter change, scroll.
- 2 - RESET button: to delete alarm and fault messages  
Arrow down key: Parameter change, scroll.
- 3 - MENU key: to call up the MENU system  
Enter key: to confirm parameter change.
- 4 - LC display 2 x 16 characters
- 5 - Alarm LED 1 lights up: Insulation fault, first warning level reached.
- 6 - Alarm LED 2 lights up: Insulation fault, second warning level reached.
- 7 - External test button (N/O contact)
- 8 - External reset button (N/C contact or wire jumper). When the terminals are open, the fault message will not be stored.
- 9 - Alarm relay: Alarm 2
- 10 - Alarm relay: Alarm 1

Wiring diagram – Mains connection

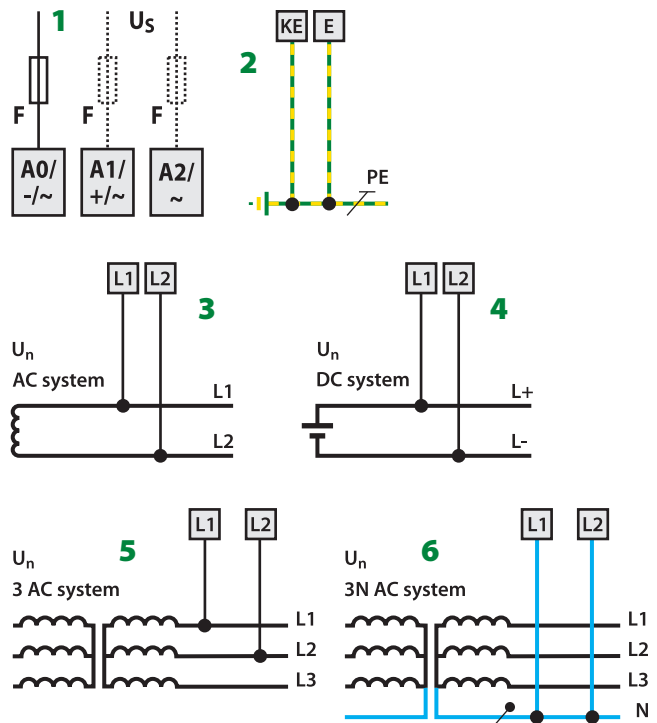
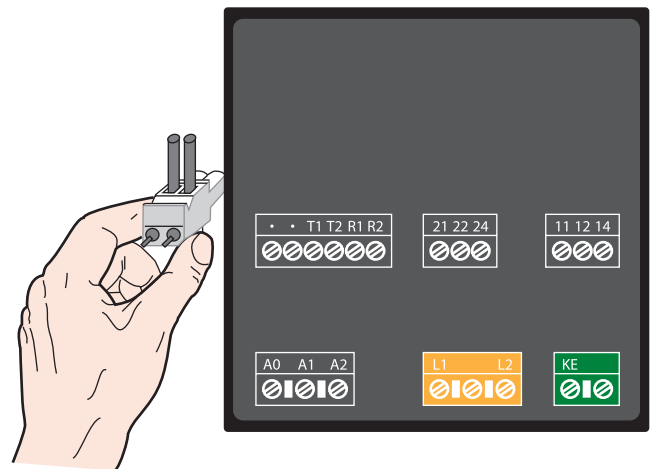

- 1 - Supply voltage  $U_s$  (see nameplate) via 6 A fuse:  
A0 - A1 = AC 88 ... 264 V, DC 77 ... 286 V  
A0 - A2 = AC 340 ... 460 V
- 2 - Separate connection of E, KE to PE
- 3 - Connection to the AC system to being monitored: Connect terminals L1, L2 to conductor L1, L2.
- 4 - Connection of the DC systems being monitored: Connect terminal L1 to conductor L+ and terminal L2 to conductor L-
- 5,6 - Connection of the 3AC system being monitored:  
Connect the terminals L1, L2 to neutral conductor N or terminals L1, L2 to conductor L1, L2.

1.5

## Technical data A-ISOMETER® IR1575

### Insulation coordination acc. to IEC 60664-1

Rated insulation voltage	AC 500 V
Rated impulse voltage/pollution degree	4 kV/3

### Voltage ranges

Nominal system voltage $U_n$	AC, 3(N)AC 0...480 V, DC 0...480 V
Rated frequency $f_n$	DC, 30...420 Hz
Supply voltage $U_S$	see ordering information
Power consumption	≤ 5 VA

### Response values

Response value $R_{an1}$ (ALARM 1)	2 kΩ...1 MΩ
Response value $R_{an2}$ (ALARM 2)	2 kΩ...1 MΩ
Relative percentage error	0...+20%/min. +2 kΩ
Response time $t_{an}$ at $R_F = 0.5 \times R_{an}$ and $C_e = 1 \mu F$	≤ 5 s
Measuring time	see characteristic curve
Hysteresis	25%

### Measuring circuit

Measuring voltage $U_m$	± 20 V
Measuring current $I_m$ (at $R_F = 0 \Omega$ )	≤ 170 μA
Internal DC resistance $R_i$	≥ 119 kΩ
Impedance $Z_i$ at 50 Hz	≥ 14 kΩ
Permissible extraneous DC voltage $U_{fg}$	DC 680 V
Permissible system leakage capacitance $C_e$	60 μF

### Displays

Display (illuminated)	LC display
Characters (number of characters, height)	2 x 16 (4.5 mm)
Display range, measuring value	1 kΩ...5 MΩ
Absolute error (1 kΩ...10 kΩ)	± 1 kΩ
Relative percentage error (10 kΩ...5 MΩ)	± 10%

### Outputs

Test and reset button	internal/external
-----------------------	-------------------

### Switching elements

Number of switching elements	2 x 1 changeover contact
Operating principle	N/C operation / N/O operation
Factory setting	N/O operation
Contact class	IIB (IEC 60255-0-20)
Rated contact voltage	AC 250 V/DC 300 V
Making capacity	AC/DC 5A
Breaking capacity	2 A, AC 230 V, cos phi 0.4 0.2 A, DC 220 V, L/R = 0.04 s
Minimum contact current at DC 24 V	2 mA (50 mW)

### General data

Shock resistance IEC 60068-2-27 (during operation)	15 g/11 ms
Bumping IEC 60068-2-29 (during transport)	40 g/6 ms
Vibration resistance IEC 60068-2-6 (during operation)	1 g/10...150 Hz
Vibration resistance IEC 60068-2-6 (during transport)	2 g/10...150 Hz
Ambient temperature (during operation)	-10 °C...+55 °C
Ambient temperature (during storage)	-40 °C...+70 °C
Climatic class acc. to DIN IEC 60721-3-3	3K5
Operating mode	continuous operation
Mounting position	display-oriented
Connection type	plug-in terminals
Connection rigid/flexible	0.2...4/0.2...2.5 mm <sup>2</sup>
Connection flexible with connector sleeve, without/with plastic sleeve	0.25...2.5 mm <sup>2</sup>
Conductor sizes (AWG)	24-12
Tightening torque	0.5...0.6 Nm (4.3...5.3 lb-in)
Degree of protection, internal components (IEC 60529)	IP30
Degree of protection, terminals (IEC 60529)	IP20
Mounting	panel mounting
Flammability class	UL94V-2
Product standards	DIN EN 61557-8:1998-05 EN 61557-8:1997-03, IEC 61557-8:1997-02, ASTM F1669M-96
Operating manual	TGH1370
Weight	≤ 400 g

## Measuring time

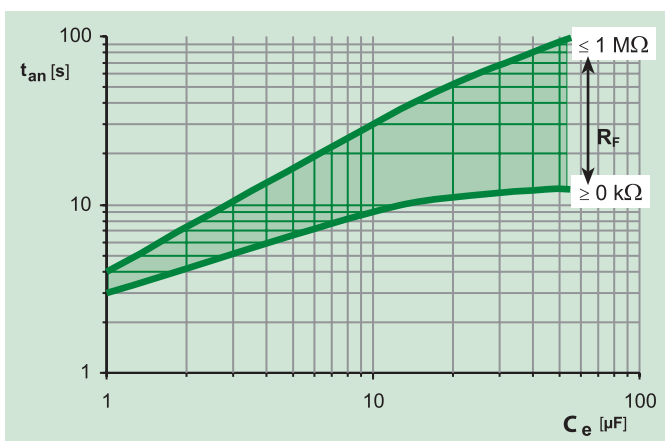

## Ordering information

Type	Supply voltage $U_S$	Art. No.
IR1575-435	AC 88...264 V/DC 77...286 V/AC 340...460 V	B 9106 4000
IR1575W-435		B 9106 4000W

## Dimension diagram

Dimensions are given in mm

