

A-ISOMETER® IR470LY2-60...

Insulation monitoring device for unearthed AC and 3(N)AC systems (IT systems) and de-energized loads

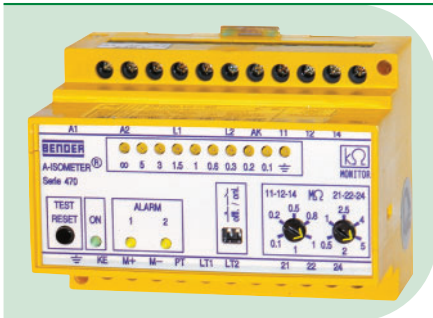

IR470LY2-60

Device features

- Insulation monitoring for unearthed AC/3(N)AC systems 0...793 V
- Off-Line monitoring for TN, TT and IT systems 0...793 V
- Nominal voltage extendable via coupling device
- Operating mode selectable: Insulation monitoring/offline monitoring
- Two separately adjustable response values 100 kΩ...1 MΩ/500 kΩ...5 MΩ
- Connection monitoring system/earth
- LEDs: Power On LED, alarm LEDs for insulation faults AC, L+, L-
- LED bar graph indicator for the insulation resistance
- Connection for kΩ indication
- Combined test/reset button
- Two separate alarm relays with one changeover contact each
- N/O or N/C operation
- Fault memory behaviour, selectable

Approvals



Product description

The A-ISOMETER® of the IR470LY2 series is designed to monitor the insulation resistance of unearthed AC and three-phase systems (IT systems) AC/3(N)AC 0...793 V. The device series is particularly suitable for systems requiring a high insulation level. The device can also be used for monitoring de-energized loads. Two separately adjustable response values/alarm relays allow a distinction to be made between "prewarning" and "alarm". In combination with a coupling device the device series can be used for higher voltages.

The systems to be monitored should not contain DC components. Due to the measuring principle, insulation faults behind directly connected rectifiers are indicated with increased response sensitivity. The set response values apply to the pure AC system only.

Application

- AC/3(N)AC main circuits (without directly connected rectifiers), such as motors, pumps, rolling mills without variable-speed drives, air cooling and air conditioning systems, lighting systems, heating systems, mobile generators, building services, domestic electrical installation practice, etc.
- De-energized loads, such as fire extinguisher pumps, slide-valve drives (gas, water, oil etc.), flue gas valves, cranes

Function

When the insulation resistance between the system conductors and earth falls below the set response value, the alarm relays switch and the alarm LEDs light up. In case of interruption of the system or earth connection, the alarm LEDs flash. The measured value is indicated on the LED bar graph indicator or a measuring instrument that can be connected externally. In this way any changes, for example when circuits are connected to the system, can be recognized easily. The fault messages can be stored. The fault memory can be reset by pressing the reset button. The device function can be tested using the test button.

Measuring principle

Superimposed DC voltage with inverter (see chapter "Annex" – "Technical aspects...").

Off-line mode

In this mode, the insulation monitoring process is automatically activated when the system voltage between the terminals L1 and L2 falls below 80 V. Only if the system voltage has fallen below this value, the device assumes that the load is de-energized. If the voltage between the terminals L1 and L2 exceeds 80 V, insulation monitoring will be automatically deactivated. This is signalled by a flashing LED ∞ of the LED line.

Ordering information

Type	Supply voltage U _s	Art. No.
IR470LY2-60	AC 230 V	B 9104 8010
IR470LY2-6013	AC 90...132 V*	B 9104 8013
IR470LY2-6015	AC 400 V	B 9104 8009
IR470LY2-6021	DC 9,6...84 V*	B 9104 8014

Other supply voltages on request* Absolute values

Accessories

External kΩ measuring instruments

Type	Art. No.
7204-1621	B 986 700
9604-1621	B 986 782

Coupling devices

Type	Nominal system voltage U _n	Art. No.
AGH520S	AC 0...7200 V	B 913 033

Dimension diagram X470

Dimensions are given in mm

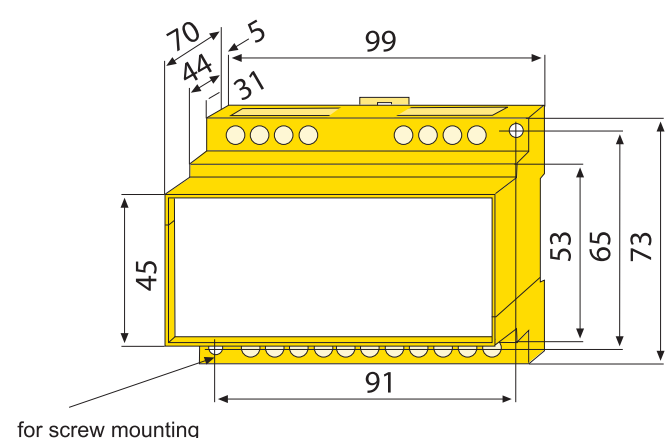

Wiring diagram – Operating elements

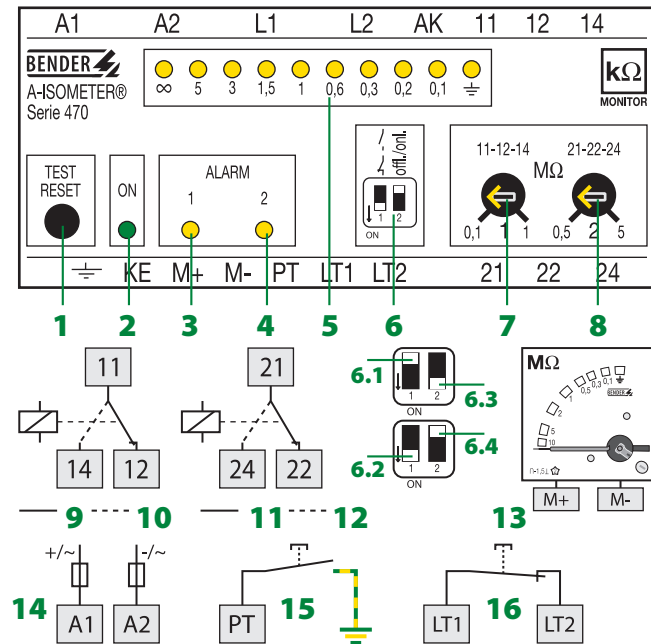

- 1 - Combined test/reset button "TEST/RESET", short-time pressing (< 1 s) = RESET, long-time pressing (> 2 s) = TEST
- 2 - Power On LED "ON"
- 3 - Alarm LEDs, yellow, light when the value falls below the set response value and flash in case of interruption of the connecting leads E/KE or L1/L2.
- 5 - LED bar graph indicator
- 6 - Operating principle of the alarm relay online/offline
 - 6.1 - N/O operation 6.2 - N/C operation
 - 6.3 - Offline 6.4 - Online
- 7 - Potentiometer to set the response value R_{an1} (Alarm 1)
- 8 - Potentiometer to set the response value R_{an2} (Alarm 2)
- 9 - Alarm relay 1: N/O operation (basic setting)
- 10 - Alarm relay 1: N/C operation
- 11 - Alarm relay 2: N/O operation (basic setting)
- 12 - Alarm relay 2: N/C operation
- 13 - External MΩ indicating instrument
- 14 - U_S see ordering information, 6 A fuse recommended
- 15 - External test button
- 16 - External reset button or contact bridge for fault memory

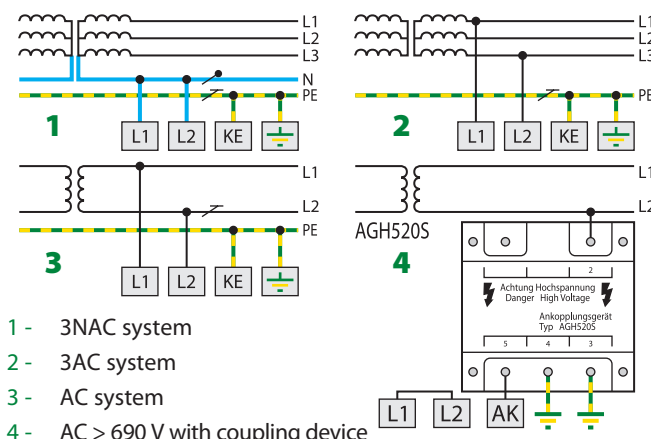

- 1 - 3NAC system
- 2 - 3AC system
- 3 - AC system
- 4 - AC > 690 V with coupling device

Technical data A-ISOMETER® IR470LY2-60

Insulation coordination acc. to IEC 60664-1

Rated insulation voltage	AC 630 V
Rated impulse voltage/pollution degree	6 kV/3

Voltage ranges

Nominal system voltage U_n	AC, 3(N)AC 0...793 V
Rated frequency f_n	40...460 Hz
Supply voltage U_S	see ordering information
Operating range of U_S	0.8...1.15 x U_S
Frequency range U_S	50...460 Hz
Power consumption	≤ 3 VA

Response values

Response value R_{an1} (Alarm 1)	100 kΩ...1 MΩ
Response value R_{an2} (Alarm 2)	500 kΩ...5 MΩ
Response time t_{an} at $R_F = 0.5 \times R_{an}$ and $C_e = 1 \mu F$	≤ 4 s

Measuring circuit

Measuring voltage U_m	≤ 40 V
Measuring current I_m (bei $R_F = 0 \Omega$)	≤ 33 μA
Internal DC resistance R_i	≥ 1.2 MΩ
Impedance Z_i at 50 Hz	≥ 1 MΩ
Permissible extraneous DC voltage U_{fg}	≤ 800 V
Permissible system leakage capacitance	≤ 10 μF

Outputs

Test/reset button	internal/external
Current output for measuring instrument (scale centre point = 120 kΩ)	0...400 μA
Load	≤ 25 kΩ

Switching elements

Number of switching elements	2 x 1 changeover contact
Operating principle	N/O operation / N/C operation
Factory setting	N/O operation
Electrical service life, number of cycles	12000
Contact class	IIB in accordance with DIN IEC 602550-20
Rated contact voltage	AC 250 V/DC 300 V
Making capacity	AC/DC 5 A
Breaking capacity	2 A, AC 230 V, cos phi = 0,4 0.2 A, DC 220 V, L/R = 0.04 s
Minimum contact current at DC 24 V	2 mA (50 mW)

General data

Shock resistance IEC 60068-2-27 (during operation)	15 g/11 ms
Bumping IEC 60068-2-29 (during transport)	40 g/6 ms
Schwingungsbeanspruchung IEC 60068-2-6 (during operation)	1 g 10...150 Hz
Vibration resistance IEC 60068-2-6 (during transport)	2 g 10...150 Hz
Ambient temperature (during operation)	-10 °C...+55 °C
Ambient temperature (during transport)	-40 °C...+70 °C
Climatic class acc. to DIN IEC 60721-3-3	3K5
Operating mode	continuous operation
Mounting	any position
Connection	screw terminals
Connection properties rigid/flexible	0.2...4 mm ² /0.2...2.5 mm ²
Degree of protection, internal components (DIN EN 60529)	IP 30
Degree of protection, terminals (DIN EN 60529)	IP 20
Screw mounting	2 x M4
DIN rail mounting acc. to	DIN EN 60715/IEC 60715
Flammability class	UL94V-0
Product standards	DIN EN 61557-8: 1998-05 EN 61557-8: 1997-03, IEC 61557-8: 1997-02 ASTM F1669M-96, ASTM F1134-94

Operating manual	BP104002
Weight approx.	360 g