

## WF Series

Flexible, Split-Core AC Current Transformers  
Used with RCMS Ground Fault Monitor Series



## WF series

Flexible current transformers  
WF170, WF250, WF500, WF800, WF1200



WF... series current transformers

### Device features

- Flexible, split-core current transformer in different lengths
- Allows quick and easy installation in hard to reach areas
- Easy retrofitting into existing installations
- Can be installed without the need to disconnect conductors
- CT connection monitoring
- For RCMS460 / 490 series ground fault monitors
- Analog output (U, I) for external measuring devices
- RCC420 with push-wire terminals (two terminals per connection)

### Approvals and certifications



### Product description

The WF... series of flexible, split-core type current transformers are highly sensitive measuring tools which measure AC currents and convert them into evaluatable signals. These are specially designed to operate with the RCMS460 and RCMS490 series of ground fault monitors for grounded and high-resistance grounded systems.

The assembly consists of one flexible WF... current transformer and one RCC signal converter. Connection to the respective evaluator is via a two-wire cable.

### Application

- Ground fault monitoring in grounded and high-resistance grounded systems
- Monitoring of systems that cannot be shut off

### Installation instructions

- All conductors, including the neutral if it is being used, should be routed through the current transformer
- The ground wire should NOT be routed through the current transformer
- Conductors should pass centrally through the current transformer
- Do not place the measuring current transformer close to strong magnetic fields

### Wiring diagram

Connection to RCMS series ground fault monitor:

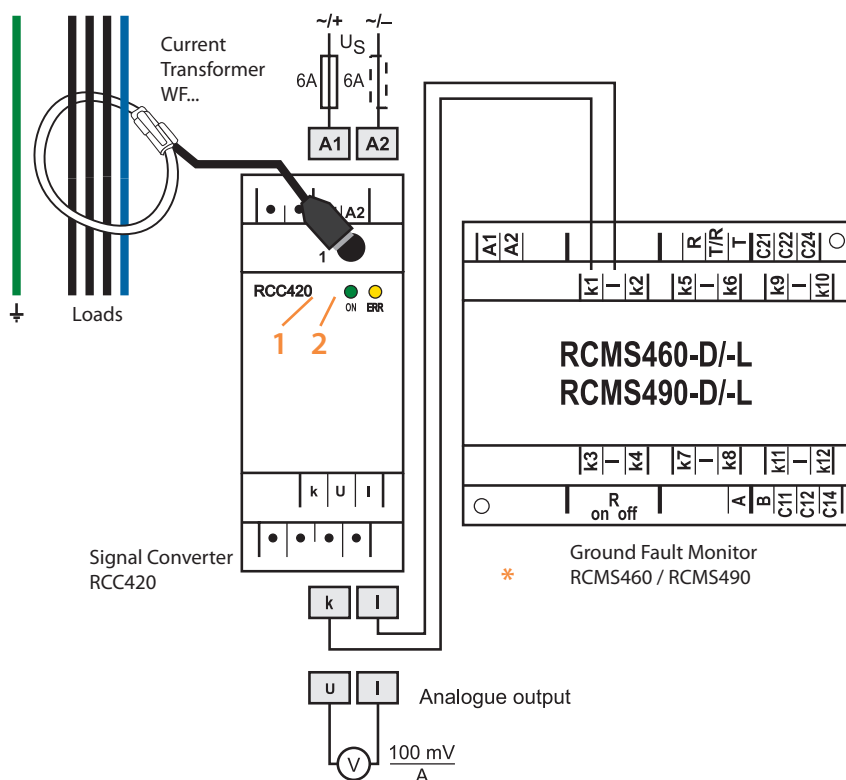

- 1 - Power On LED "ON": lights up when voltage is available and when the device is in operation
- 2 - Alarm LED "ERR": Lights during a connection error

\* - Important settings for RCMS:

Up to software version D233 V 2.21  
Switch off CT monitoring

Software version D233 V 2.31 and higher  
Set the CT type to "flex"

(The software version of the RCMS may be checked by pressing the INFO key)

## Technical data

### Electrical safety

|                                    |                                       |
|------------------------------------|---------------------------------------|
| Standard: RCC420                   | IEC 61010-2-030: 2004-05-01           |
| Pollution degree                   | 3                                     |
| Rated insulation voltage           | 250 V                                 |
| Standard: WF...                    | IEC 1010-1 and IEC 1010-2-032 CAT III |
| Pollution degree                   | 2                                     |
| Rated insulation voltage (CAT III) | 1000 Vrms or DC                       |

### Supply voltage

|                      |                          |
|----------------------|--------------------------|
| Supply voltage $U_s$ | see ordering information |
| Power consumption    | $\leq 3$ VA              |

### Measuring circuit

|  |   |
|--|---|
| Measuring range                            | 100 mA...20 A   |
| Rated transformation ratio                 | $K_N (U - I): 100 \text{ mV} / A, K_N (k - I): 1.67 \text{ mA} / A$ |
| Rated burden (signal outputk, I)           | 68 $\Omega$   |
| Rated frequency                            | 42...2000 Hz  |
| Rated continuous thermal current $I_{cth}$ | 1 kA  |
| Rated short-time thermal current $I_{th}$  | 60 kA / 1 s   |
| Rated dynamic current $I_{dyn}$            | 150 kA / 40 ms  |

### EMC

|   |  |
|---|--|
| Operating temperature                             | -25 °C...+55 °C                                |
| Climatic class acc. to IEC 60721                  |  |
| Stationary use (IEC 60721-3-3)                    | 3K5 (except condensation and formation of ice) |
| Transport (IEC 60721-3-2)                         | 2K3 (except condensation and formation of ice) |
| Long-time storage (IEC 60721-3-1)                 | 1K4 (except condensation and formation of ice) |
| Classification of mechanical conditions IEC 60721 |  |
| Stationary use (IEC 60721-3-3)                    | 3M4  |
| Transport (IEC 60721-3-2)                         | 2M2  |
| Long-time storage (IEC 60721-3-1)                 | 1M3  |

### Connection RCC420

|  |                                       |
|--|---------------------------------------|
| Connection type                                | push-wire terminals                   |
| Connection properties rigid                    | 0.2...2.5 mm <sup>2</sup> / AWG 24-14 |
| Flexible without ferrule                       | 0.2...2.5 mm <sup>2</sup> / AWG 24-14 |
| Flexible with ferrule                          | 0.2...1.5 mm <sup>2</sup> / AWG 24-16 |
| Stripping length                               | 10 mm                                 |
| Opening force                                  | 50 N                                  |
| Test opening, diameter                         | 2.1 mm                                |
| Connection measuring current transformer W...F | PS / 2 plug                           |
| Cable length W...F                             | 2 m                                   |

### Cable lengths RCMS-RCC420...

|  |                       |
|--|-----------------------|
| Single wire $\geq 0.75 \text{ mm}^2$                                       | 0...1 m               |
| Single wire twisted $\geq 0.75 \text{ mm}^2$                               | 0...10 m              |
| Shielded cable $\geq 0.5 \text{ mm}^2$                                     | 0...40 m              |
| Recommended cable (shielded, shield to terminal I, not connected to earth) | J-Y(ST)Y min. 2 x 0.8 |

### Other

|   |   |
|---|---|
| Operating mode  | continuous operation  |
| Mounting  | any position  |
| Degree of protection, internal components / terminal (DIN EN 60529) | IP 30 / IP 20   |
| Enclosure material RCC420   | polycarbonate   |
| Flammability class  | UL94V-0   |
| DIN rail mounting acc. to   | IEC 60715   |
| Screw mounting  | 2 x M4 with mounting clip   |
| Operating manual  | TBP409020   |
| Weight  | RCC 420 $\leq 160$ g    WF500 $\leq 200$ g<br>WF170 $\leq 160$ g    WF800 $\leq 230$ g<br>WF250 $\leq 180$ g    WF1200 $\leq 310$ g |

## Ordering information

| Type     | Length A measuring current transformer | Supply voltage $U_s^*$                    | Art. No.    |
|----------|--|---|-------------|
| WF170-1  | 170 mm                                 | DC 9.6...94 V / AC 42...460 Hz 16...72 V  | B 7808 0201 |
| WF170-2  | 170 mm                                 | DC 70...300 V / AC 42...460 Hz 70...300 V | B 7808 0202 |
| WF250-1  | 250 mm                                 | DC 9.6...94 V / AC 42...460 Hz 16...72 V  | B 7808 0203 |
| WF250-2  | 250 mm                                 | DC 70...300 V / AC 42...460 Hz 70...300 V | B 7808 0204 |
| WF500-1  | 500 mm                                 | DC 9.6...94 V / AC 42...460 Hz 16...72 V  | B 7808 0205 |
| WF500-2  | 500 mm                                 | DC 70...300 V / AC 42...460 Hz 70...300 V | B 7808 0206 |
| WF800-1  | 800 mm                                 | DC 9.6...94 V / AC 42...460 Hz 16...72 V  | B 7808 0207 |
| WF800-2  | 800 mm                                 | DC 70...300 V / AC 42...460 Hz 70...300 V | B 7808 0208 |
| WF1200-1 | 1200 mm                                | DC 9.6...94 V / AC 42...460 Hz 16...72 V  | B 7808 0209 |
| WF1200-2 | 1200 mm                                | DC 70...300 V / AC 42...460 Hz 70...300 V | B 7808 0210 |

\* Absolute values

## Accessories

| Type   | Art. No.    |
|--|-------------|
| Mounting clip for XM420 enclosure (RCC420)<br>(one unit required per device) | B 9806 0008 |

**Note:** The measuring current transformer is adapted to the associated signal converter RCC420.

### Dimensions: XM420

Dimensions in mm

Open the front plate cover in direction of arrow!

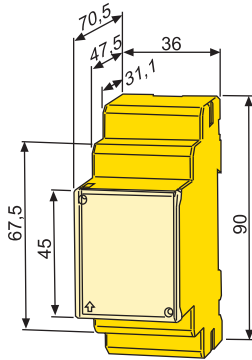

### Screw mounting

Note: The upper mounting clip must be ordered separately (see "Accessories")

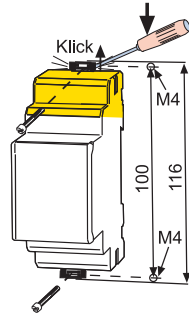

### Dimensions: Current Transformer

A = For details about the length of the measuring current transformer refer to ordering information

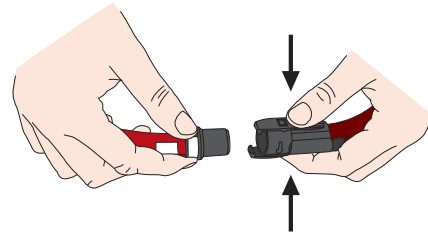
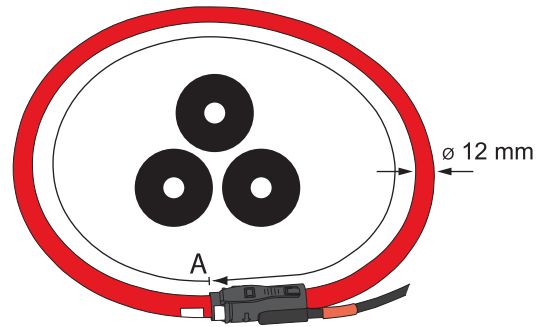

Locking connector measuring current transformer W500F...W1200F  
Keep the locking connector clean

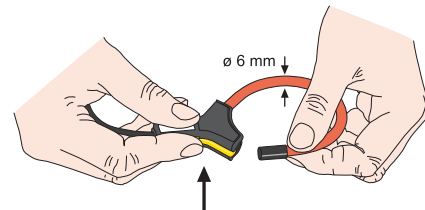

Locking connector measuring current transformer W170F...W250F



North American Headquarters  
700 Fox Chase • Coatesville, PA 19320  
Toll-Free: 800-356-4266 • Fax: 610-383-7100

USA, West Coast Office  
4555 West Chermak St • Burbank, CA 91505  
Toll-Free: 800-236-3378 • Fax: 818-565-3552

Canada  
5 Edvac Dr, Unit 14 • Brampton, ON L6S 5P3  
Toll-Free: 800-243-2438 • Fax: 905-799-3051

[www.bender.org](http://www.bender.org) • E-mail: [info@bender.org](mailto:info@bender.org)