

FTC470XMB

Modbus/RTU Communication Gateway
For Supported BENDER Devices



FTC470XMB

Modbus/RTU communication gateway
For supported BENDER devices



FTC470XMB

Description

The FTC470XMB is a Modbus/RTU communication gateway for supported BENDER devices. Up to 10 BENDER devices may be connected to one FTC470XMB, and allows for full integration into existing Modbus/TCP communication systems.

The FTC470XMB is recommended for retrofitting existing systems with Modbus/RTU networks. For a communication gateway supporting Modbus/TCP, please refer to the COM460IP.

Applications

- Remote communication of BENDER devices information to Modbus/RTU networks
- Control of BENDER devices via Modbus/RTU
- Connecting to Modbus/RTU compatible building management systems

Device features

- Modbus/RTU communication gateway for supported BENDER devices

Function

The FTC470XMB is integrated into a Modbus/RTU network as a slave device, and is integrated into the BENDER communication bus as either a master or a slave. The appropriate Modbus/RTU controller must be programmed to interpret the data from the FTC470XMB. A complete command syntax may be found in the FTC470XMB user manual.

Approvals



Operating elements

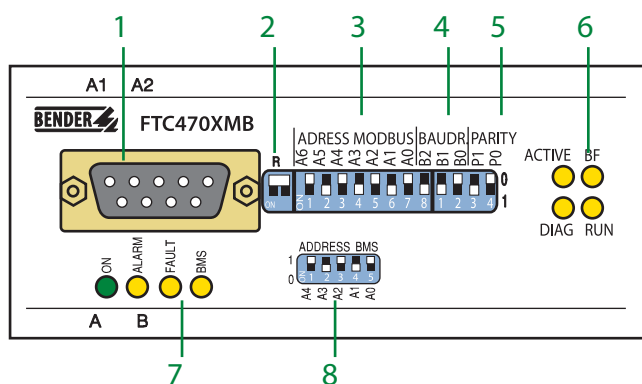

- 1 - Socket for Modbus RTU cable: 9-pin SUB-D
- 2 - Micro switch for Modbus RTU termination: "ON" = terminating resistor activated
- 3 - DIP switches for binary addressing of Modbus RTU: 1...127
- 4 - DIP switches for binary baud rate setting of Modbus RTU: 1200...57600 bit/s
- 5 - DIP switches for binary parity setting of Modbus RTU: none/even/odd
- 6 - Modbus RTU status indication
- 7 - BMS bus status indication
- 8 - DIP switches for binary BMS bus address setting: 1...30

Wiring diagram

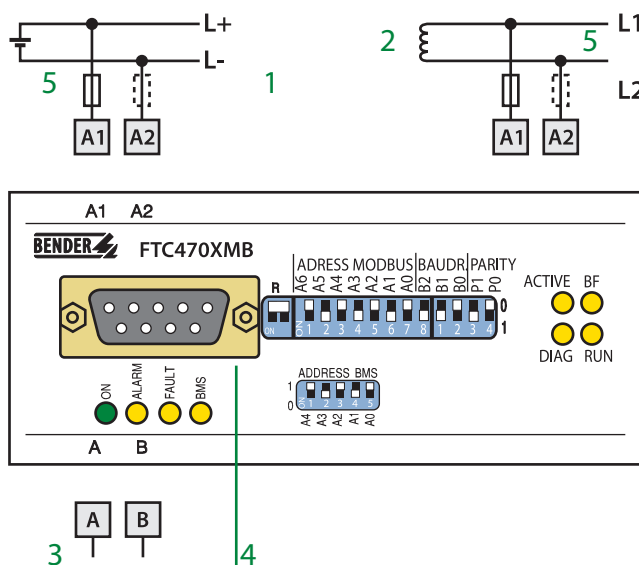

- 1 - System connection $U_S = DC\ 85...276\ V$
- 2 - System connection $U_S = AC\ 85...276\ V$
- 3 - BMS bus connection
- 4 - Modbus-RTU 9-pin SUB-D
- 5 - U_S see ordering information, 6 A fuse recommended

Technical Data

Insulation coordination acc. to IEC 60664-1

Rated insulation voltage	AC 250 V
Rated impulse voltage/pollution degree	4 kV/3

Supply voltage

Supply voltage U_s	see ordering information
Frequency range of U_s	DC, 50...400 Hz
Power consumption	≤ 12 VA

Interfaces

BMS

Interface/protocol	RS-485/BMS (internal)
Baud rate	9.6 kbit / s
Cable length	≤ 1200 m
Recommended cable (shielded, shield connected to PE on one side)	min. J-Y (St)Y 2 x 0.6
Mode	Master/Slave
Connection	terminals A/B
Terminating resistor	120 Ω (0.25 W)
Device address, BMS bus	DIP switch 1...30
Alarm LEDs	ON/Alarm/FAULT/BMS

Modbus

Interface/protocol	RS-485/Modbus RTU
Mode	Modbus RTU slave
Connection	9-pin SUB-D
Alarm LEDs	Active/bus error/Diag/Run
Baud rate	1.2...57.6 kbit/s
Terminating resistor	DIP switch
Address assignment Modbus RTU	DIP switches 1...127

General data

EMC immunity	acc. to EN 61000-6-2
EMC emission	acc. to EN 61000-6-4
Classification of climatic conditions acc. to IEC 60721	
Stationary use	3K5
Transport	2K3
Long-time storage	1K4
Operating temperature	-10 °C...+55 °C
Classification of mechanical conditions acc. to IEC 60721	
Stationary use	3M4
Transport	2M2
Long-time storage	1M3
Operating mode	continuous operation
Mounting	any position
Connection	screw-type terminals
Connection properties	
rigid/flexible/conductor sizes	0.2...4/0.2...2.5 mm /AWG 22-12
flexible with ferrule, without/with plastic sleeve	0.25...2 mm
Stripping length	8 mm
Tightening torque	0.5 Nm
Degree of protection, internal components (IEC 60529)	IP 30
Degree of protection, terminals (IEC 60529)	IP 20
Type of enclosure/dimension diagram	X470
Screw mounting	2 x M4
DIN rail mounting acc. to	IEC 60715
Flammability class	UL94V-0
Operating Manual	TGH1367
Weight	≤ 360 g

Ordering information

Type	Supply voltage U_s	Art. No.
FTC470XMB	AC/DC 85...276 V*	B 9506 1002

*Absolute value

Dimensions

Dimensions in mm

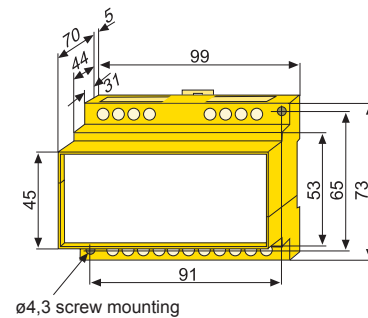



North American Headquarters • Coatesville, PA
Toll-Free: 800.356.4266 • Fax: 610.383.7100

Canada • Brampton, ON
Toll-Free: 800-243-2438 • Fax: 905-799-3051

www.bender.org • E-mail: info@bender.org