

SUR357Z

SUR358Z

Undervoltage and overvoltage relays for 3AC or 3NAC systems without external supply voltage



SUR358Z

Device features

- Undervoltage and overvoltage monitoring for 3AC / 3NAC systems
- No external supply voltage required
- SUR357Z Common alarm relay for both undervoltage and overvoltage
- SUR358Z Separate alarm relays for undervoltage and overvoltage
- Adjustable response value $0.7 \dots 0.95 \times U_n / 1.05 \dots 1.3 \times U_n$
- Nominal system voltages 3AC 100 V, 110 V, 230 V, 400 V, 440 V, 500 V, 690 V
- Adjustable response delay 0.5...5 s
- Alarm LED
- Alarm relay with two potential-free changeover contacts

Approvals



Product description

The relays of the SUR357Z/358Z series are designed to monitor the voltage of three-phase AC systems. The relays can be used for both undervoltage and overvoltage monitoring (window function). Neutral conductor connection is not required, hence the relays are suitable for 3AC and 3NAC systems. Supply voltage and measuring voltage are galvanically separated. Special input transformers attenuate interferences from the system. The devices include an input circuit protection.

Typical applications

- Monitoring of the power supply of motors and electrical installations
- Monitoring of loads
- Switching on and switching off at a certain voltage level
- Monitoring of stand-by and emergency supply systems
- Supply voltage monitoring of portable loads

Function SUR357Z

When the supply voltage applied is within the set response range, the alarm relay works in N/C operation (relay energized) and the alarm LED lights up. When the system voltage U_n exceeds the set response value $< U_n$, the alarm LED goes out. When the voltage exceeds the response value $> U_n$ the alarm LED goes out. The common alarm relay switches after the response delay has elapsed. If the response values are again within the set response range, the SUR357Z switches back to its original state after approx. 200 ms.

Funktion SUR358Z

When the supply voltage applied is within the set response range, the alarm relay K1 for undervoltage works in N/C operation (relay energized) and the alarm relay K2 for overvoltage works in N/O operation (relay de-energized). When the system voltage U_n drops below the set response value $< U_n$, the alarm LED " $< U_n$ " lights up and the alarm relay K1 switches after the response delay has elapsed. When the system voltage U_n exceeds the set response value $> U_n$, the alarm LED " $> U_n$ " lights up and the alarm relay K2 switches after the set response delay has elapsed. When the response values are again within the set response range, the SUR358Z switches back to its original state after approx. 200 ms.

Note

False alarms resulting from short-time operational measurement errors can be suppressed by setting a time delay. In case of complete system failure, the time delay is not effective, except for the device operating time. If the delay function is to be maintained in case of complete system failure, the energy backup SP100 is recommended to be used.



Wiring diagram SUR357Z

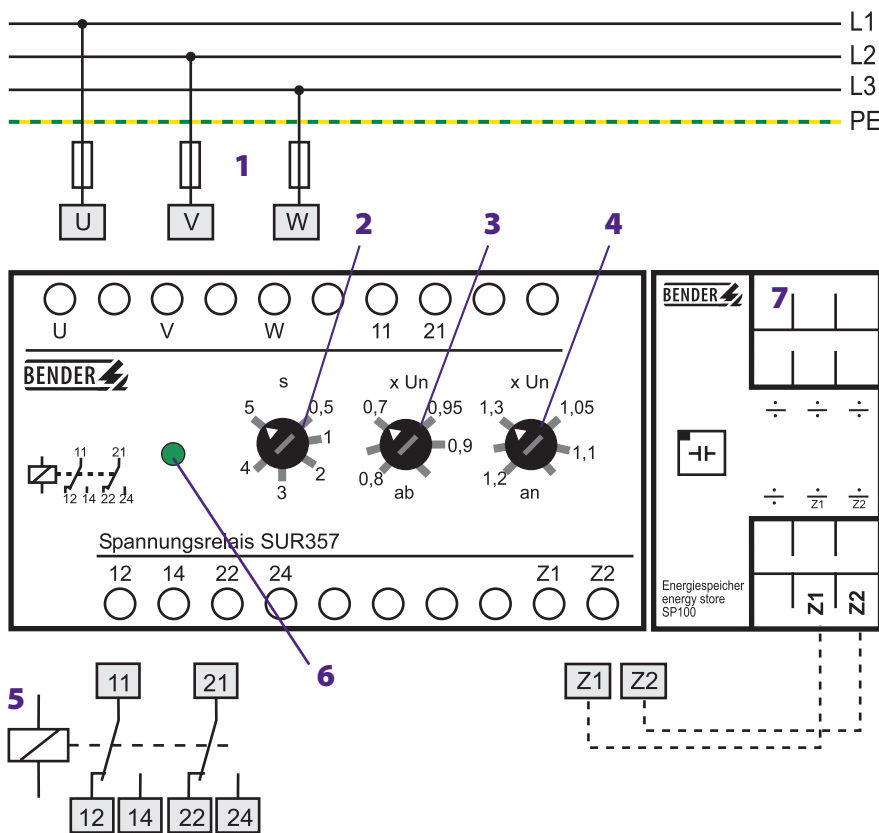

- 1 - 6 A fuse
- 2 - Setting potentiometer for response delay "S"
- 3 - Setting potentiometer for undervoltage "xUn"
- 4 - Setting potentiometer for overvoltage "xUn"
- 5 - Alarm relay with two changeover contacts
- 6 - Alarm LED lights under normal conditions and goes out in the event of overvoltage, undervoltage and system failure.
- 7 - SP100 energy backup
SP100 energy backup for a duration of max. five seconds. An additional means to delay the time in the event of complete system failure.

Wiring diagram SUR358Z

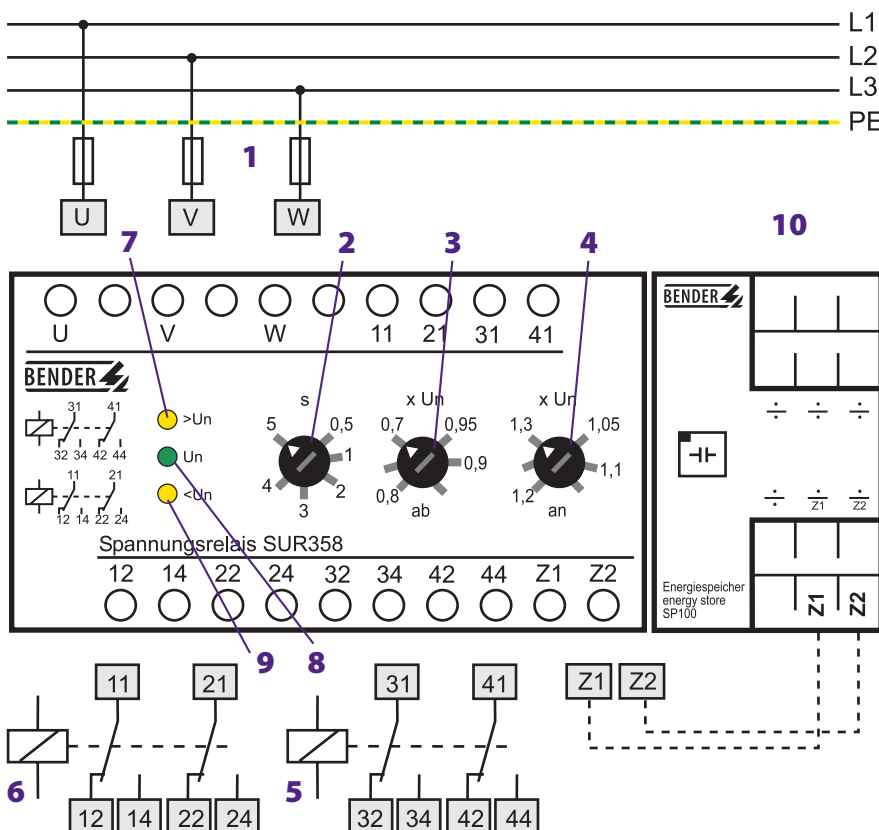

- 1 - 6 A fuse
- 2 - Setting potentiometer for response delay "S"
- 3 - Setting potentiometer for undervoltage "xUn"
- 4 - Setting potentiometer for overvoltage "xUn"
- 5 - Alarm relay K2 for signalling overvoltage
- 6 - Alarm relay K1 for signalling undervoltage
- 7 - Alarm LED lights in the event of overvoltage ">Un"
- 8 - Power ON LED "Un"
- 9 - Alarm LED "<Un" lights in the event of undervoltage
- 10 - SP100 energy backup
SP100 energy backup for a duration of max. five seconds. An additional means to delay the time in the event of complete system failure.

Technical data undervoltage and overvoltage relays SUR357Z / 358Z

Insulation coordination acc. to IEC 60664-1

Rated insulation voltage	AC 690 V
Rated impulse voltage/pollution degree	6 kV/3

Supply voltage

Supply voltage U_s	none
Power consumption	≤ 6 VA

Measuring circuit

Nominal system voltage U_n	see ordering information
Operating range of U_n	0.5...1.3 x U_n
Frequency f_n	50/60 Hz
Response values undervoltage	0.7...0.95 x U_n
Response values overvoltage	1.05...1.3 x U_n
Response delay t	0.5...5 s
Hysteresis	approx. 2 %
Delay on release	approx. 200 ms

Switching elements

Number of changeover contacts	SUR357Z	1 x 2
	SUR358Z	2 x 2
Operating principle	SUR357Z	N/C operation
	SUR358Z undervoltage	N/C operation
	SUR358Z overvoltage	N/O operation
Electrical service life, number of cycles		12000
Contact class IEC 60255 Part 0-20		IIB
Rated contact voltage		AC 250 V/DC 300 V
Limited making capacity		AC/DC 5 A
Breaking capacity		2 A, AC 230 V, $\cos \phi$ 0.4
		0.2 A, DC 220 V, L/R = 0.04 s

Environment / EMC

EMC immunity	acc. to IEC 61000-6-2
EMC emission	acc. to IEC 61000-6-4
Shock resistance IEC 60068-2-27 (during operation)	15 g/11 ms
Bumping IEC 60068-2-29 (during transport)	40 g/6 ms
Vibration resistance IEC 60068-2-6 (during operation)	1 g / 10...150 Hz
Vibration resistance IEC 60068-2-6 (during transport)	2 g / 10...150 Hz
Ambient temperature, during operation	-10...+50 °C
Ambient temperature, during storage	-20...+70 °C
Climatic class acc. to IEC 60721-3-3	3K5 (except condensation and formation of ice)

Other

Operating mode	continuous operation
Mounting	any position
Connection	Flat terminals with self-lifting clamp washers
Connection properties	
single wire	2 x (1...1.5) mm ²
flexible with end ferrules	2 x (0.75...1.5) mm ²
Degree of protection, internal components (IEC 60529)	IP50
Degree of protection, terminals/with terminal covers (IEC 60529)	IP10/IP20
Screw fixing	refer to dimension diagram
DIN rail mounting acc. to	IEC 60715
Flammability class	UL94V-0
Product standard	IEC 60255-6
Operating manual	BP301007
Weight	≤ 700 g

Dimension diagram X200 Dimensions in mm

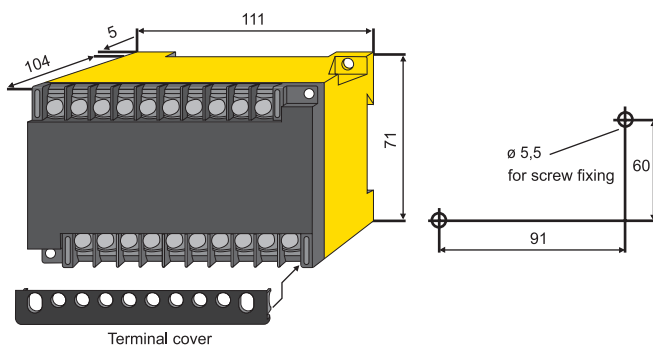

Ordering information

Type	Nominal system voltage U_n	Art. No.
SUR357Z	3AC 100 V	B 933 603
SUR357Z	3AC 110 V	B 933 200
SUR357Z	3AC 230 V	B 933 153
SUR357Z	3AC 400 V	B 933 697
SUR357Z	3AC 500 V	B 933 053
SUR357Z	3AC 690 V	B 933 014
SUR358Z	3AC 100 V	B 933 605
SUR358Z	3AC 110 V	B 933 217
SUR358Z	3AC 230 V	B 933 155
SUR358Z	3AC 400 V	B 933 701
SUR358Z	3AC 500 V	B 933 055
SUR358Z	3AC 690 V	B 933 709
Other voltages on request		
SP100	Energy backup	B 935 700